

MeetingBar A30 Deployment & Connection

Package Contents

TIP

For the MeetingBar A30 unboxing video, please refer to [Video: MeetingBar A30 Unboxing](#).

• Standard accessories



MeetingBar A30

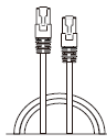

(3 m, 9.84 ft)
CAT5e UTP (RJ45 - RJ45) Cable



(1.8 m, 5.91 ft)
HDMI 2.0 Cable
(for the display device)



(20 * 200 mm)
Cable Ties

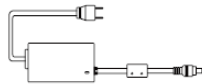

(3.5 m, 11.48 ft)
Power Adapter (48 V/0.7 A)

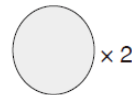

(φ38*T1.2mm)
Silicone Pad

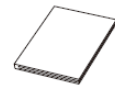

Quick Start Guide



Mounting Bracket



φ6 * 30 mm, white, Polyamide

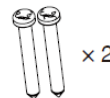

4*30 FAHOZN3+ (+)



1/4" -20 UNC

• Optional accessories

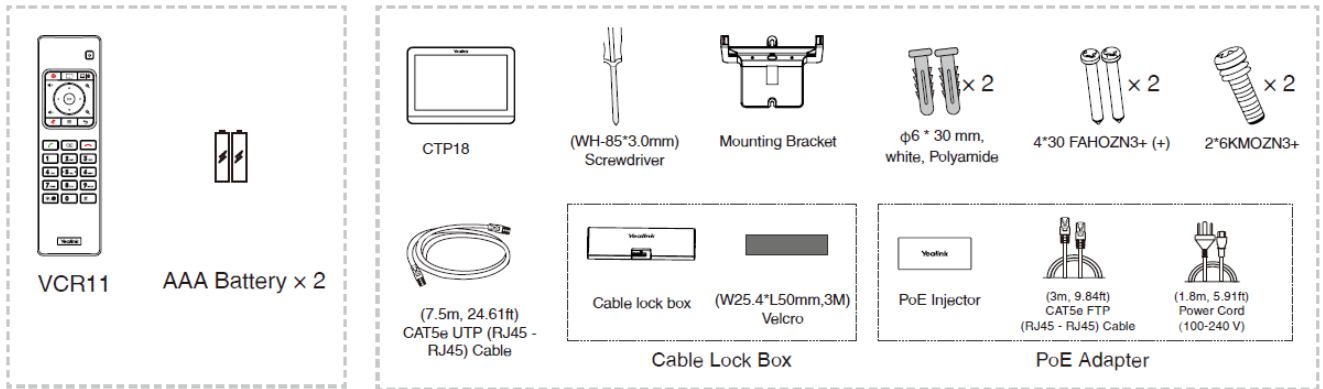

Remote Control Package

Touch Panel Package
(Standard accessory on Zoom edition)

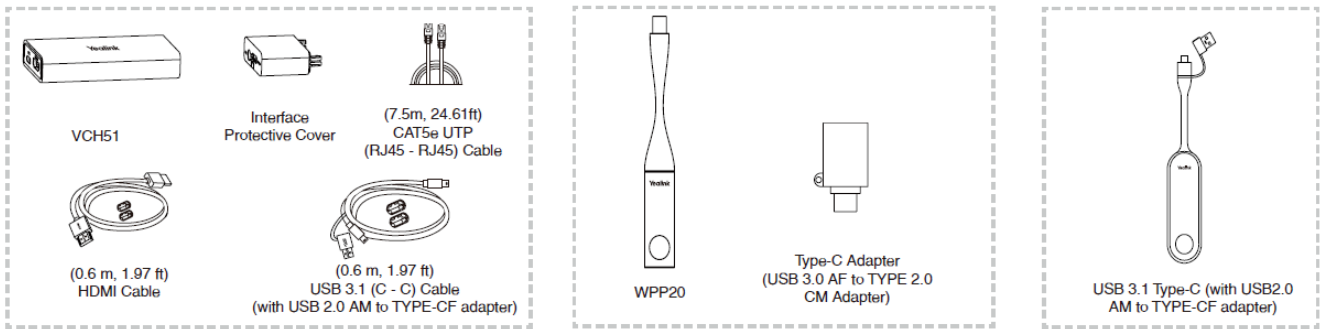

VCH51 Sharing Kit

Wireless Presentation Pod-WPP20

Wireless Presentation Pod-WPP30

Remove Protective Shell

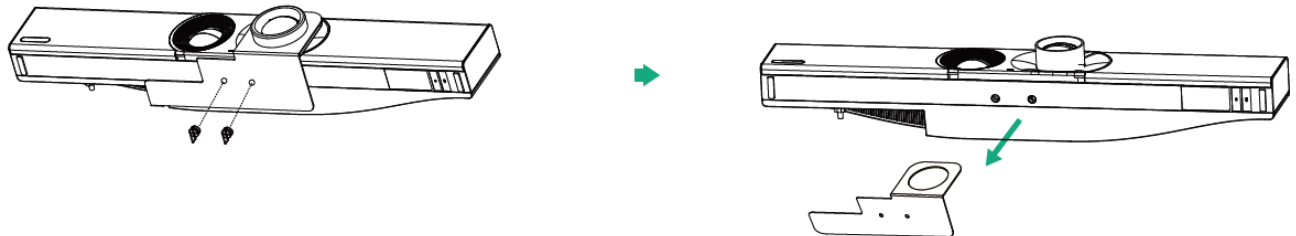

Install MeetingBar A30

Mount it on a wall

1. Determine MeetingBar A30 position

The mounting height affects your camera view. The recommended height is 1.1 m above the ground.

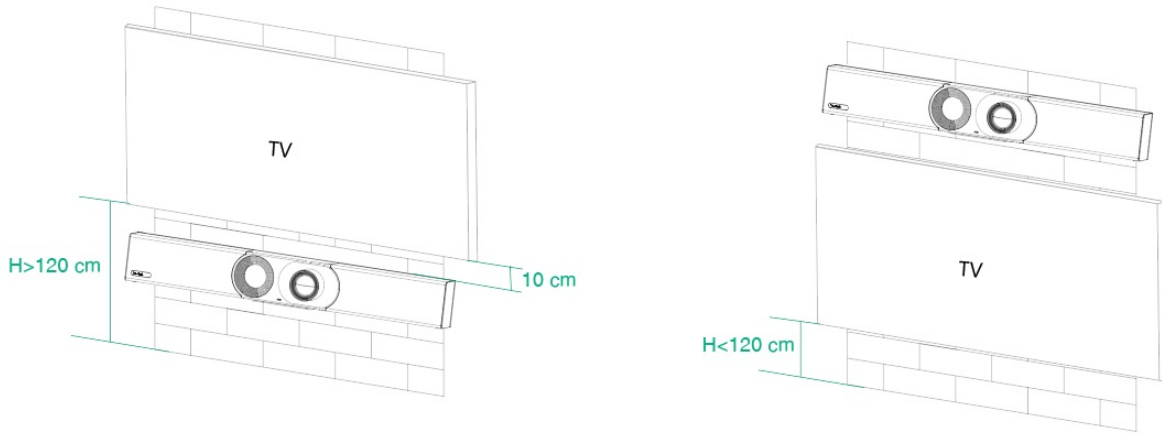

NOTE

Embedded installation is prohibited (For example: inside the wall, enclosed space).



2. Install mounting bracket

Step 4: Expansion Screws: $\phi 6 * 30$ mm. Hole depth: 6 mm, Hole diameter: 30 mm.

Step 5: Screws: 4*30 FAHOZN3+ (+)

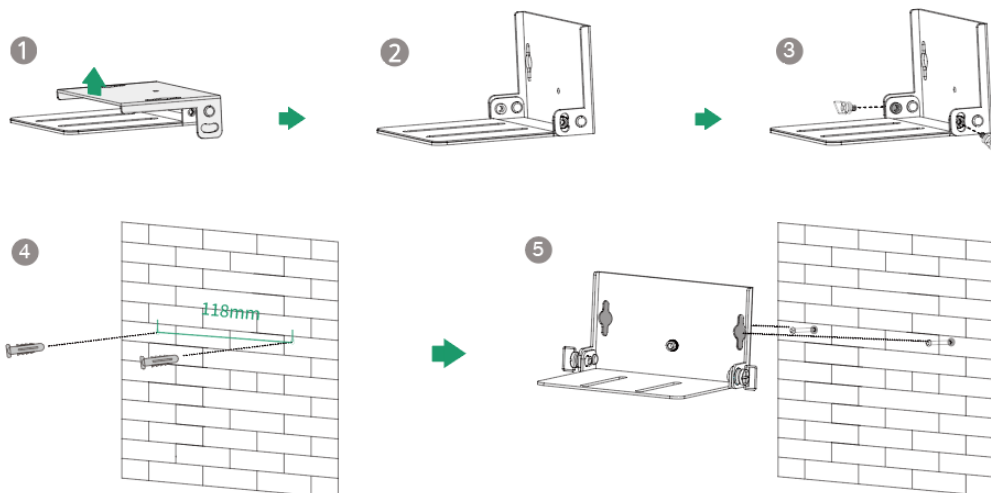

3. Mount it to bracket

Screws: 1/4" -20 UNC

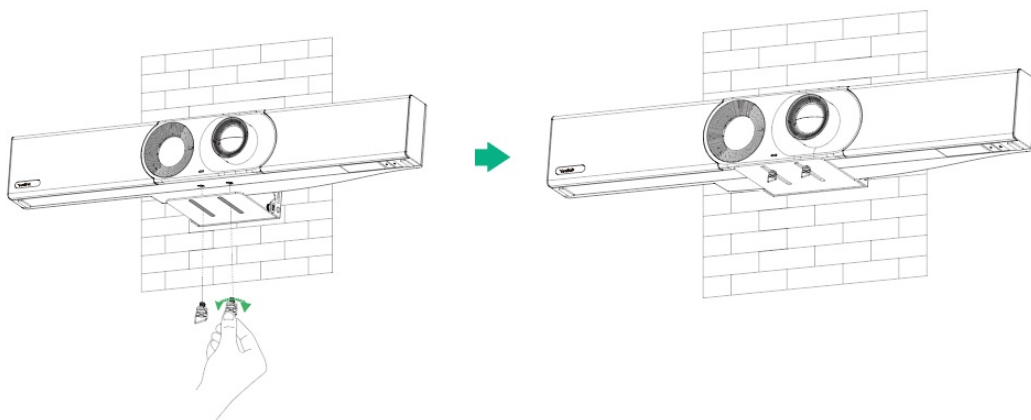

Mount it on TV stand cart platform

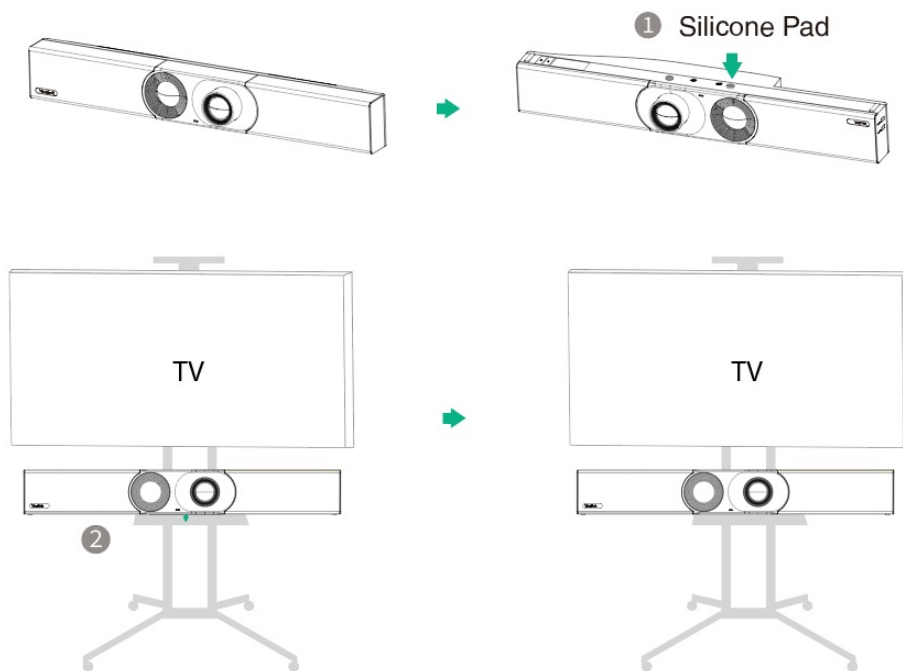

Put it on a desk

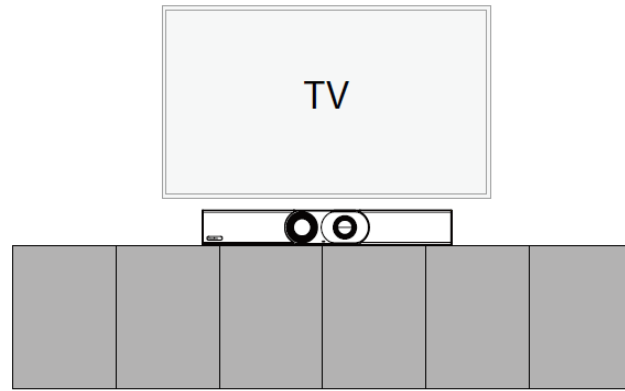

Adjust Camera Tilt

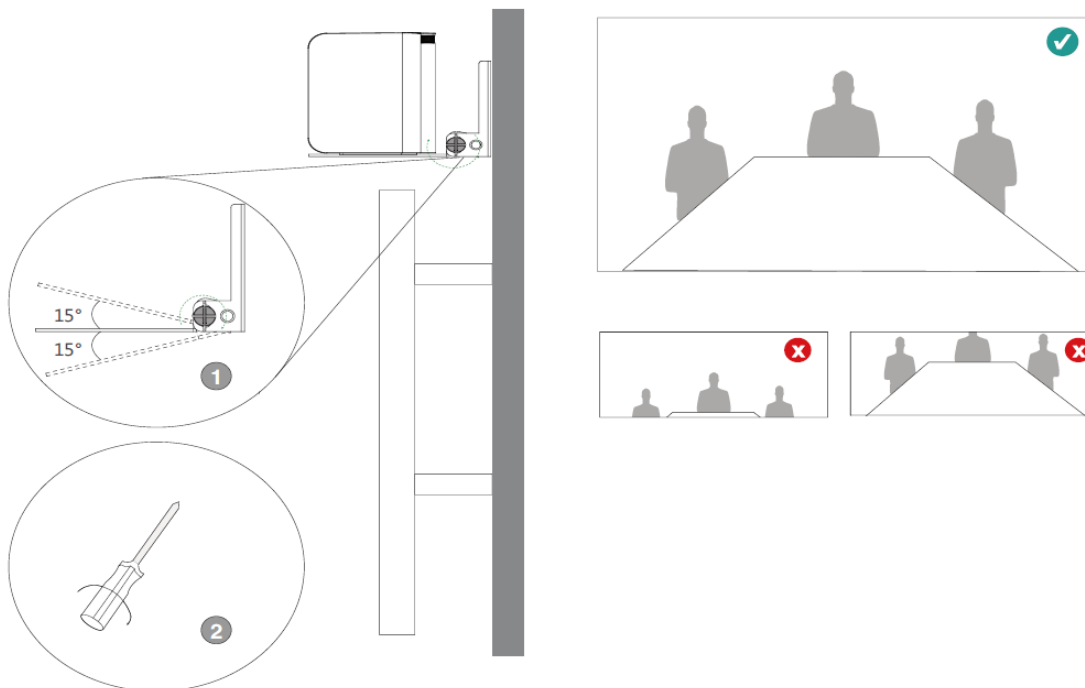

Connect/Pair MeetingBar A30

For a better pairing experience, we recommend starting the MeetingBar A30 first and then the CTP18. The MeetingBar A30 and CTP18 must be on the same LAN or connected to the same Wi-Fi before pairing and completing the setup.

You can power the CTP18 through PoE, as shown in the figure below.

After the deployment and connection are successful, please refer to [Quick Setup](#) to complete the setup wizard, and refer to [Quick Usage](#) to learn about getting started quickly.

NOTE

If you only use one display, please connect to HDMI 1 port. The functions of the VC hub/phone port and the VC Hub/ Internet port are different, and please pay attention to the connection method when using.

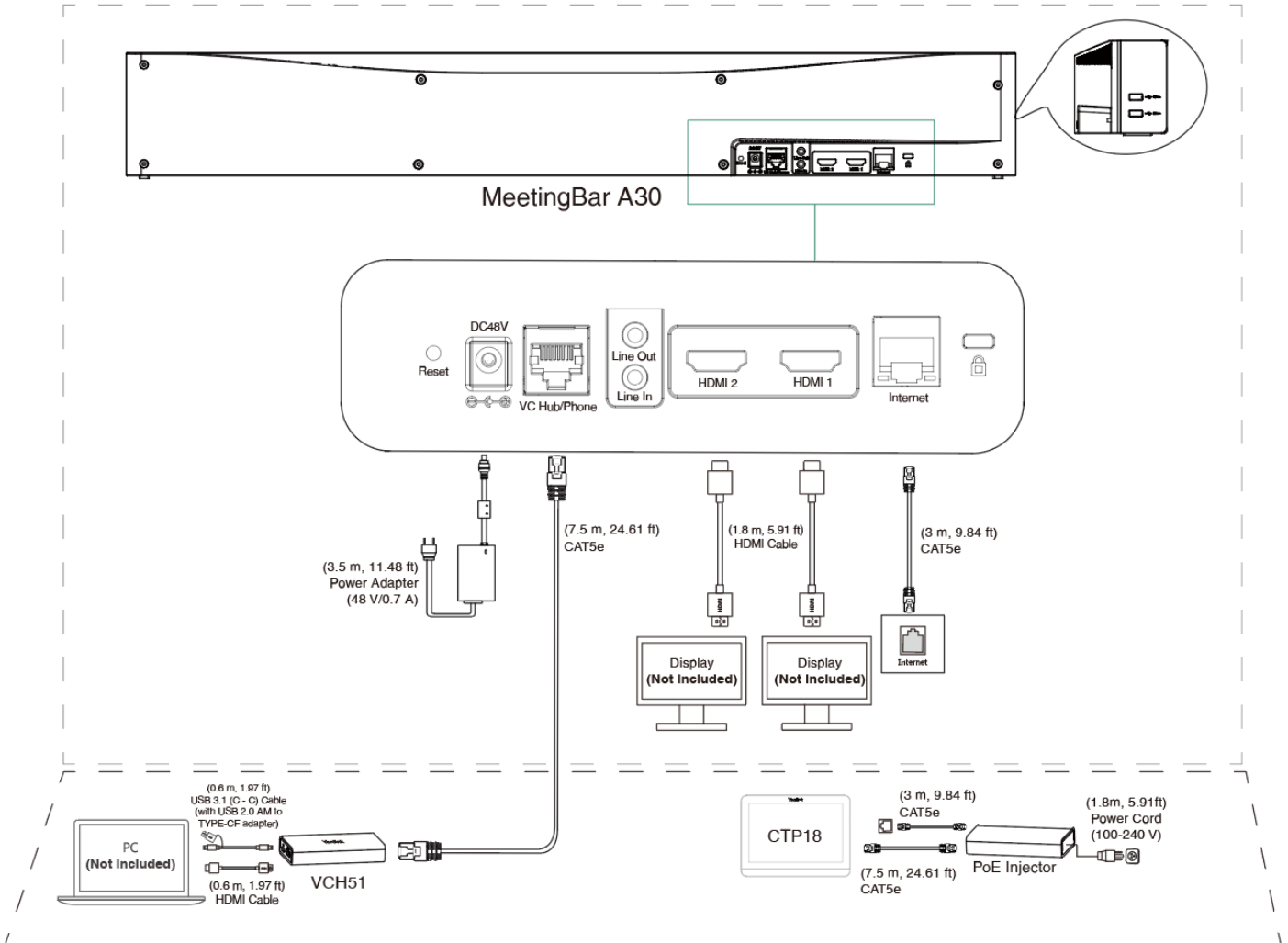

NOTE

Not included accessories requirements:

- Display: Resolution of 1080p or higher and with an HDMI port.
- PC: Equipped with HDMI or USB-C (support DP protocol) Port.

Supported Accessories

For more information, please refer to [Teams Room Accessories Compatibility Lists](#).

FAQ

Is the A10/A20/A30 unable to obtain the network, or is the network connection abnormal?

How do I connect VCM36-W with the MeetingBar A20/A30?

How do I pair CPW90 with the MeetingBar A20/A30 Teams?

How do I connect VCM38 with the MeetingBar A20/A30?